

RCCA-A simple network topologies

Direct connection of terminals

The simplest way to create a network is to connect the terminals directly using an Ethernet cable (Fig. 1). Any port (port 1 or port 2) of the RCCA is connected to the PLC using a Profisafe cable. Other field devices are then connected to the network via the remaining port of the RCCA.

This results in a line topology that is suitable for very small, isolated networks or for connecting several door control units with each other via an RCCA (Fig. 2).

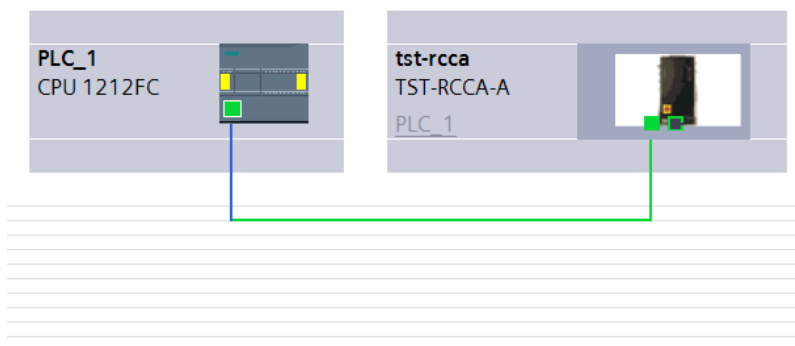

Figure 1

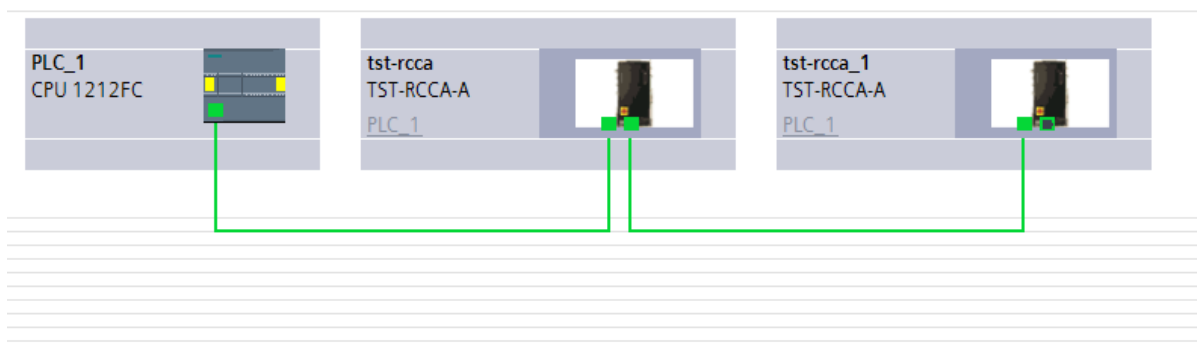

Figure 2

RCCA-A extended topology

To implement spatially separated setups, the use of an unmanaged (Fig. 3) or managed (Fig. 4) switch is recommended.

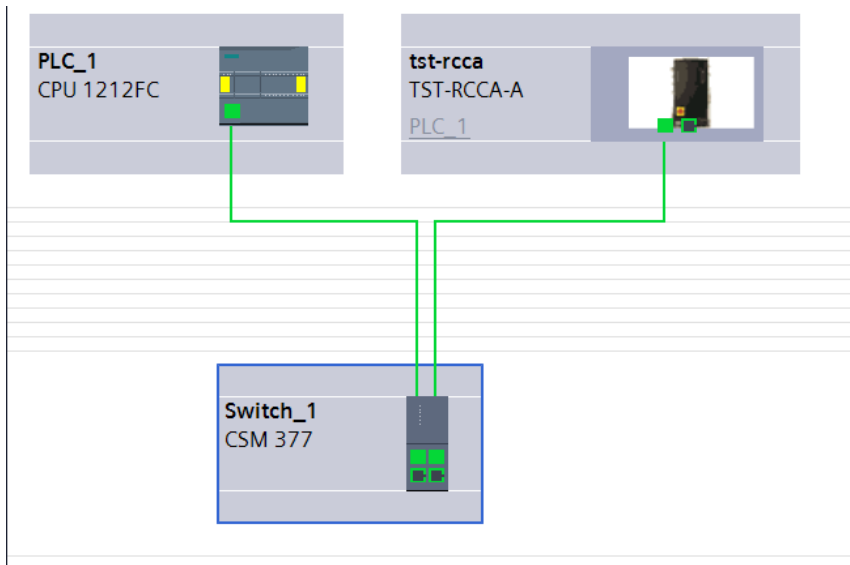

Figure 3

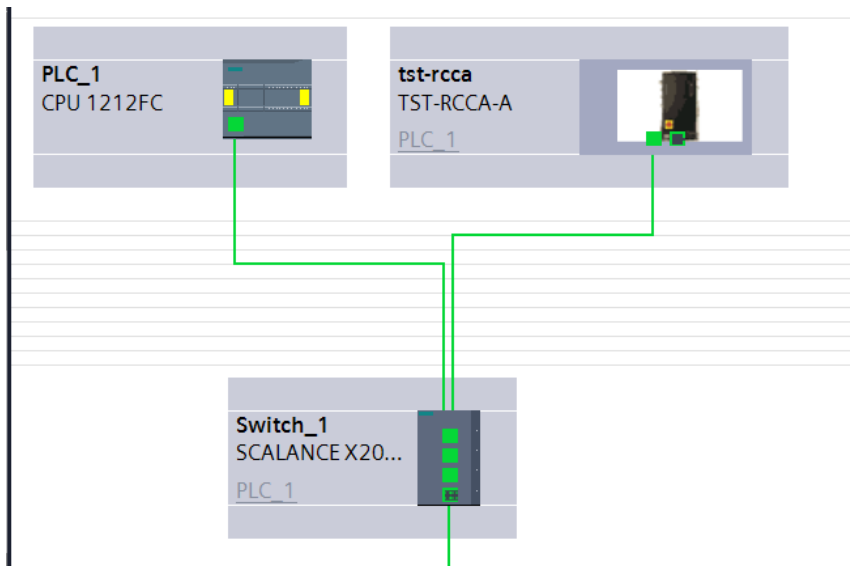

Figure 4

RCCA-A typical network

Figure 5 shows a typical network in a mixed topology in which spatially grouped door control units are connected via the switch function of the RCCA, the PLC and (managed) switch are housed in the main control cabinet and an HMI is accessible to the operator at a central point.

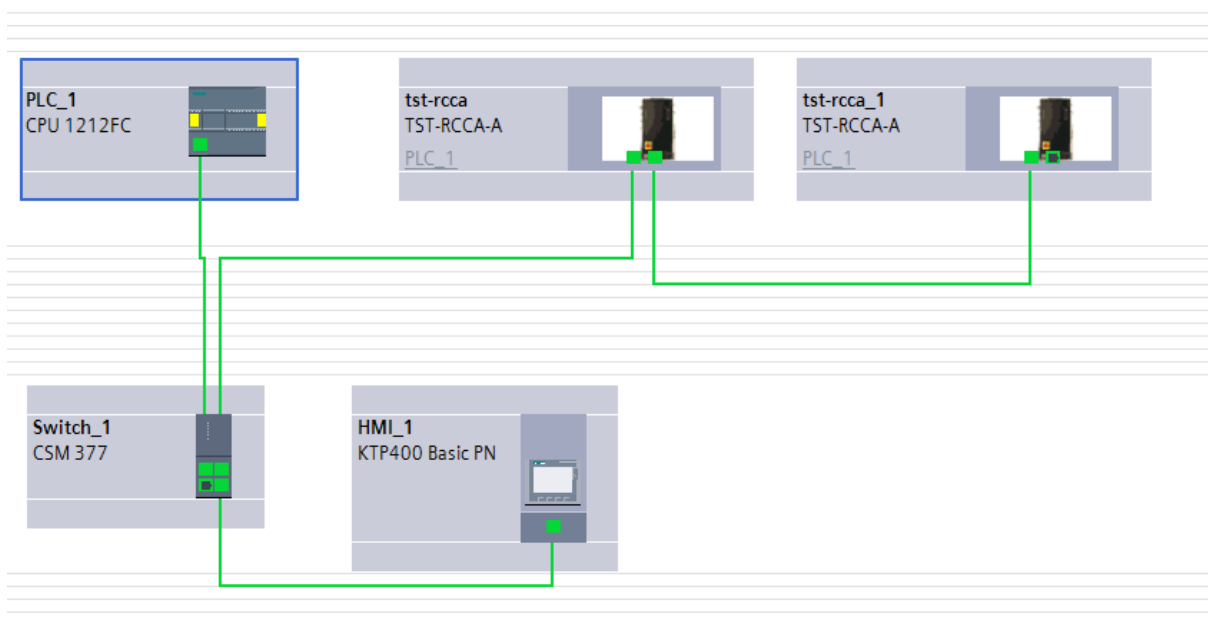

Figure 5